



INSTRUCTION MANUAL
MARKSMAN - RECEIVER HITCH SWIVEL HOIST
(Item # 02-RHOIST-001)

WEIGHT CAPACITY: **300 lbs.***

The user must confirm the weight capacity of the vehicle receiver hitch
Do Not exceed the rated capacity of the vehicle's receiver hitch

WARNING!

- Completely read and follow this manual before assembling and using this product.
- **Never** modify or alter this product. Improper installation or adjustment may cause damage to the vehicle or serious personal injury.
- **Never** exceed the maximum capacity of 300 lbs. It is up to the user to verify the vehicle's receiver hitch capacity.
- **Do Not** attempt to drive with the Receiver Hitch Swivel Hoist while it is installed to the vehicle. The hoist is designed for use on a stationary vehicle.
- **Do Not** use this product under the influence of alcohol, medication, illegal substance or any mind altering drug.
- **Never** let children play or use this product. This is not a toy!
- Keep these instructions in a safe location for future reference.

For prompt replacement of any missing or damaged parts, please call **DIRECT OUTDOOR PRODUCTS** at: **877-284-9005** (reference model # 02-RHOIST-001)

DIRECT OUTDOOR PRODUCTS
11500 South Pipeline Road
Ft. Worth, TX 76040
Phone: 1-877-284-9005
E-mail: customerservice@directoutdoorproducts.com



INSTRUCTIONS

- 1.) Verify all components are present.
- 2.) Assemble all the components as show in the assembly diagram.

Note: The last step should be feeding the Cable Assembly (Item 10) through the pulleys and securing the cable to the winch.

- 3.) Verify all hardware is tight and secure.

Assembly & Helpful Tips

- Make sure the Cable Assembly has some tension on it when winding to the winch.
- Try to evenly wind the cable to the winch spool.
- Secure the Gambrel Hook to the Storage Bracket (Item 2) when not in use. This will eliminate a potential hazard.
- Use the Pin w/ Clip (Item 20) to lock the Swivel Tower Section when rotating is not needed.

Automatic Brake Adjustment

- Before applying a load to the winch, verify that the Brake Tension is adjusted properly.
- If the cable can be easily pulled causing the winch to unwind, the tension needs to be tightened.

Brake Tension Nut is Under the Handle

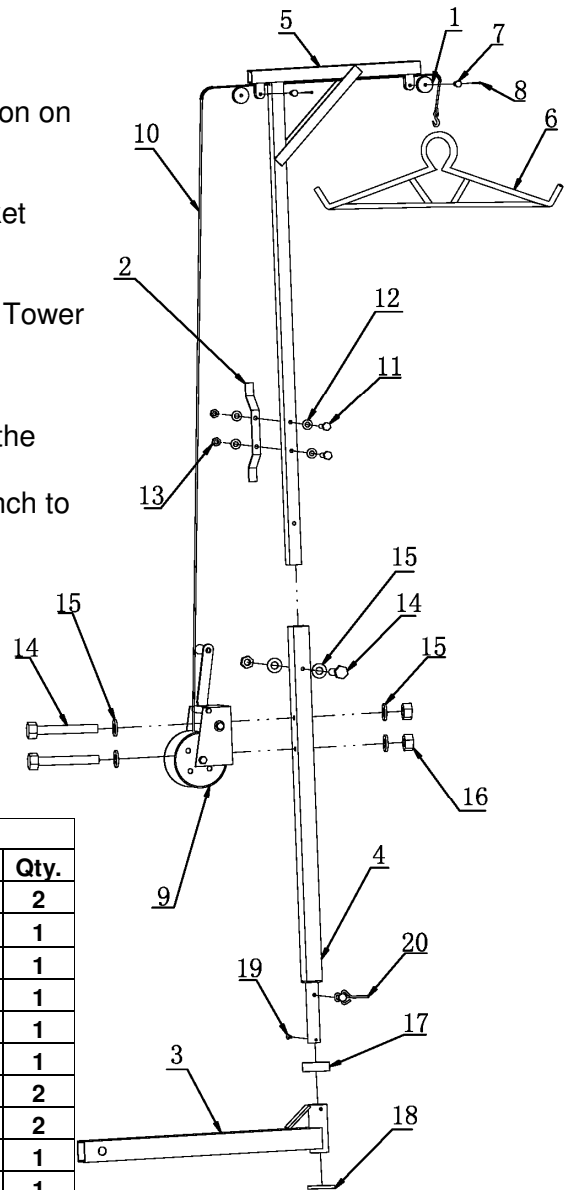
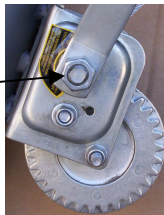

02-RHOIST-001			
Item	Part #	Description	Qty.
1	MK073-3001	CABLE PULLEY	2
2	MK073-3002	GAMBREL STORAGE BRACKET	1
3	MK073-3100	RECEIVER TUBE	1
4	MK073-3200	SWIVEL TOWER SECTION	1
5	MK073-3300	UPPER TOWER SECTION	1
6	MK073-3400	GAMBREL HOOK	1
7	51080252B	PIN 8mm x 25mm	2
8	50030202W	COTTER PIN 3mm x 20mm	2
9	91046001W	WINCH ASSEMBLY	1
10	91046002W	CABLE/HOOK ASSEMBLY	1
11	10060452B	M6 x 45mm HEX HEAD BOLT	2
12	30060002B	6mm FLAT WASHER	4
13	41060002B	M6 HEX NUT	2
14	10100552B	M10 x 55mm HEX HEAD BOLT	3
15	30100002B	10mm FLAT WASHER	6
16	41100002B	M10 HEX NUT	3
17	91881906W	THRUST BEARING ASSY.	1
18	30300002W	30mm FLAT WASHER	1
19	50050502W	COTTER PIN 5mm x 50mm	1
20	MK073-3003	PIN W/ CLIP 6mm x 70mm	1

LIMITED WARRANTY POLICY

Limited Warranty Periods

- **Hunting Equipment:** 1 Year (12 months) from the date of purchase.
- **Trailer Products:** 1 Year (12 months) from the original date of purchase.
- **Hydraulic Cylinders, Rams, Hose Assemblies, and Fittings:** 2 Years (24 months) from the date of purchase.
- **Sub-component Items:** Many sub-component items are warranted separately by the respective manufactures and are covered by warranty of their manufacturer. Examples of such items may include safety harnesses and tie-down systems, wheels, tires, axles, bearings, lights, straps, chain, hardware and like items. The sub-components original manufactures product warranty supersedes and takes precedence over this limited warranty policy.

NOTE: ALL WARRANTY CLAIMS MUST BE PREAPPROVED BY THE MANUFACTURER (THE COMPANY) TO BE VALID.

Products are warranted to be free of defects in materials and/or workmanship for the warranty period. Under this limited warranty, the Company shall be limited to repairing or replacing, at its option, for the warranty period, those parts returned to the factory, freight prepaid, which in the opinion of the Company shall prove to be defective in materials or workmanship, under normal use and service. This warranty will not apply unless the product is installed, used and maintained in accordance with the Manufacturers installation, operation and maintenance instructions.

This warranty applies to the **ORIGINAL** purchaser only, and is non-transferable. The Company warrants the products to be free of defects in material and workmanship but, does not cover normal maintenance or adjustments, damage or malfunction caused by: improper handling, installation, abuse, misuse, negligence, carelessness of operation or normal wear and tear. In addition, this warranty does not cover equipment when repairs or alterations have been made or attempted without the express written consent of the company. Product repairs not covered by the warranty, and product updates, will be provided at the prevailing rate.

The Company is not responsible for damage caused by accident, negligence, abuse, overloading, misapplication, or misuse of the products. It is solely the purchaser's responsibility to determine the suitability of these products for the particular application. **Limitations:** All other obligations or liabilities, including incidental or consequential damages or contingent liabilities arising out of the failure of any parts to operate properly are hereby excluded, including but not limited to any damages resulting from loss of use, inconvenience, loss of time, commercial loss, or any other type of damages general or specific, foreseen or unforeseen, unless applicable state law provides otherwise.

THIS WARRANTY IS EXCLUSIVE AND IS LIEU OF ALL OTHER WARRANTIES EXPRESSED OR IMPLIED INCLUDING ANY IMPLIED WARRANTY OR MERCHANTABILITY OR ANY IMPLIED WARRANTY OF FITNESS FROM A PARTICULAR PURPOSE, AND ALL SUCH IMPLIED WARRANTIES ARE EXPRESSLY EXCLUDED.

THE REMEDIES DESCRIBED ARE EXCLUSIVE AND IN NO EVENT SHALL THE COMPANY, NOR ANY SALES AGENT OR OTHER COMPANIES AFFILIATED WITH IT OR THEM, BE LIABLE FOR SPECIAL CONSEQUENTIAL OR INCIDENTAL DAMAGES FOR THE BREACH OF OR DELAY IN PERFORMANCE OF THIS WARRANTY. THIS INCLUDES, BUT IS NOT LIMITED TO, LOSS OF PROFIT, RENTAL OR SUBSTITUTE EQUIPMENT OR OTHER COMMERCIAL LOSS.

This warranty shall be governed by the laws of the State of Texas, and shall be subject to the exclusive jurisdiction of the Court in the State of Texas in the County of Tarrant.

RETURNS: Products may not be returned without written approval (Return Material Authorization) from the Company.

Direct Outdoor Products, Drop Tail Trailers, United Hydraulics, LLC

Rev04152008

